

CS5040

# Technical

description

# Technical description

CS5040 is a modern system of desks and workbenches designed for individual and team work. The minimalistic design and functionality adjusted to the user's needs reflect the idea behind the system's name CS Compact Design — Smart Solutions.

## 1. Desks

### 1.1. Table top

– Fixed table tops

– Sliding table tops (in range of 120 mm)

Both types of table tops are made of melamine faced chipboard (MFC), thickness 25 mm, with 2 mm edge in glue technology as standard, or laser edge as an option. Available shape: rectangular in wide range of dimensions. Cut outs for grommets, round and rectangular outlets as well as media ports in various types and configurations – available as an option.

### 1.2. Base

#### 4-leg

Legs – “n-shape” welded legs, made of steel profile 50 × 40 mm.

Frame – two beams made of steel profile 30 × 40 mm.

Construction – with 8 mm distance between table top and base.

#### A-leg

Legs – “A-shape” welded legs, made of steel profile 50 × 40 mm.

Frame – two beams made of steel profile 30 × 40 mm.

Construction – with 8 mm distance between table top and base.

#### 4-leg wooden

Legs – “n-shape” legs, profile 50 × 40 mm, upper part made of welded steel profile, bottom part made of solid beech wood.

Frame – two beams made of steel profile 30 × 40 mm.

Construction – with 8 mm distance between table top and base.

#### A-leg wooden

Legs – “A-shape” legs, profile 50 × 40 mm, upper part made of welded steel profile, bottom part made of solid beech wood.

Frame – two beams made of steel profile 30 × 40 mm.

Construction – with 8 mm distance between table top and base.

#### Height

Fixed height:

– 750 mm (for construction with 8 mm distance between table top and base).

Levelling in range of 10 mm.

Manual height adjustment:

– in range of 640–860 mm (not applicable to wooden legs).

#### Finish option

Metal legs:

– legs powder-coated in Traffic white (RAL 9016), Jet black (RAL 9005), White aluminium (RAL 9006), Slate grey (RAL 7015) or “Fashion Collection” colour,

– beams powder-coated only in Jet black (RAL 9005).

Wooden legs:

– metal elements powder-coated in Traffic white (RAL 9016), Jet black (RAL 9005), White aluminium (RAL 9006), Slate grey (RAL 7015) or “Fashion Collection” colour,

– wooden beech elements finished with transparent varnish (0C),

– beams powder-coated only in Jet black (RAL 9005).

All desks are unassembled as standard.

### 1.3. Product range

#### Bases

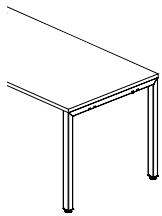

4-leg

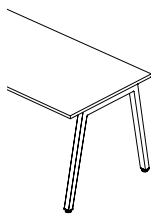

A-leg

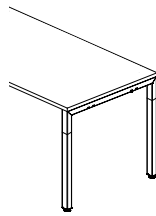

4-leg wooden

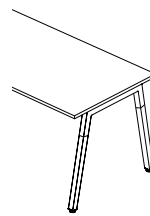

A-leg wooden

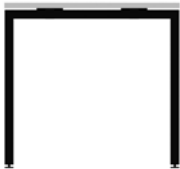

construction with distance

#### Table tops

##### Rectangular

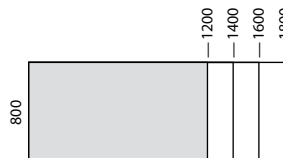
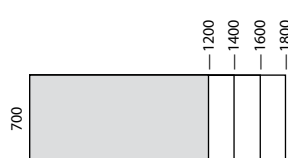
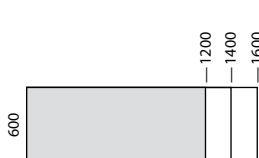

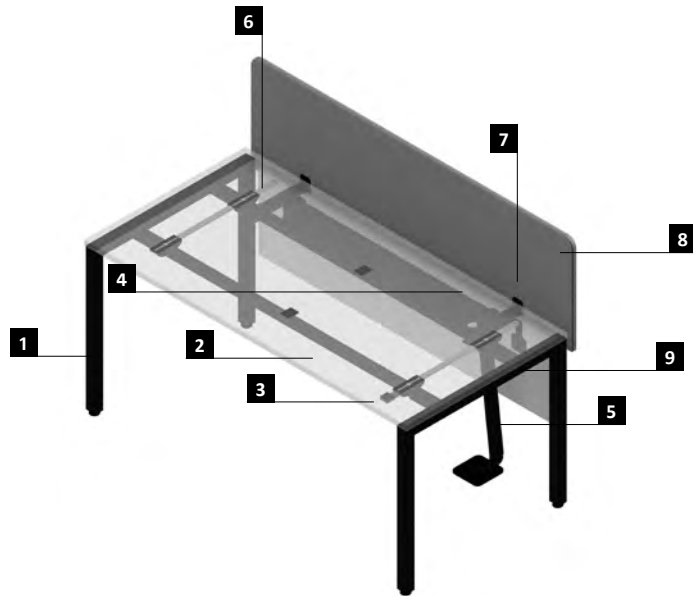

- 1** 4-leg base
- 2** Table top
- 3** Sliding release button
- 4** Horizontal wire trunking
- 5** Vertical wire trunking
- 6** Upper panel
- 7** Basic bracket
- 8** Modesty panel

## 2. Workbenches

Workbench (basic module) – face to face workstation, on four legs.

Workbench additional (additional module) – face to face workstation on two legs recessed 400 mm from table top edge, to extend workbench arrangement.

### 2.1. Table top

– Fixed table tops

– Sliding table tops (in range of 120 mm).

Both types of table tops are made of melamine faced chipboard (MFC), thickness 25 mm, with 2 mm edge in glue technology as standard, or laser edge as an option. Available shape: rectangular in wide range of dimensions. Cut outs for grommets, round and rectangular outlets as well as media ports in various types and configurations – available as an option.

### 2.2. Base

#### 4-leg

Legs – “n-shape” welded legs, made of steel profile 50 × 40 mm.

Frame – four beams made of steel profile 30 × 40 mm.

Construction – with 8 mm distance between table top and base or without distance.

#### A-leg (applicable to workbench basic module only)

Legs – “A-shape” welded legs, made of steel profile 50 × 40 mm.

Frame – four beams made of steel profile 30 × 40 mm.

Construction – with 8 mm distance between table top and base.

#### 4-leg wooden

Legs – “n-shape” legs, profile 50 × 40 mm, upper part made of welded steel profile, bottom part made of solid beech wood.

Frame – four beams made of steel profile 30 × 40 mm.

Construction – with 8 mm distance between table top and base.

#### A-leg wooden (applicable to workbench basic module only)

Legs – “A-shape” legs, profile 50 × 40 mm, upper part made of welded steel profile, bottom part made of solid beech wood.

Frame – four beams made of steel profile 30 × 40 mm.

Construction – with 8 mm distance between table top and base.

#### Height

Fixed height:

– 750 mm (for construction with 8 mm distance between table top and base).

Levelling in range of 10 mm.

Manual height adjustment:

– in range of 640–860 mm (not applicable to wooden legs).

#### Finish option

Metal legs:

– legs powder-coated in Traffic white (RAL 9016), Jet black (RAL 9005), White aluminium (RAL 9006), Slate grey (RAL 7015) or “Fashion Collection” colour,

– beams powder-coated only in Jet black (RAL 9005).

Wooden legs:

– metal elements powder-coated in Traffic white (RAL 9016), Jet black (RAL 9005), White aluminium (RAL 9006), Slate grey (RAL 7015) or “Fashion Collection” colour,

– wooden beech elements finished with transparent varnish (OC),

– beams powder-coated only in Jet black (RAL 9005).

Both modules are available with or without possibility of panel integration. Regardless of selected option (with or without panel) total depth remains 1400 mm or 1600 mm.

All workbenches are unassembled as standard.

# Technical description

## 2.3. Product range

### Bases

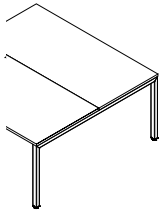

Workbench (basic module) 4-leg

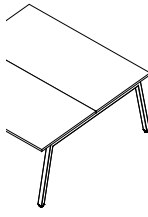

Workbench (basic module) A-leg

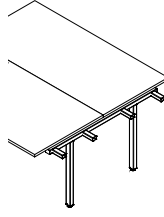

Workbench additional with recessed legs

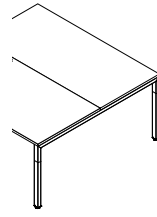

Workbench (basic module) 4-leg wooden

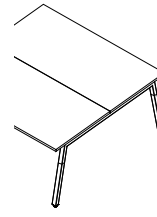

Workbench (basic module) A-leg wooden

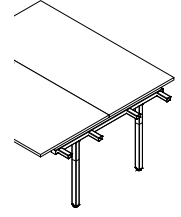

Workbench additional with recessed wooden legs

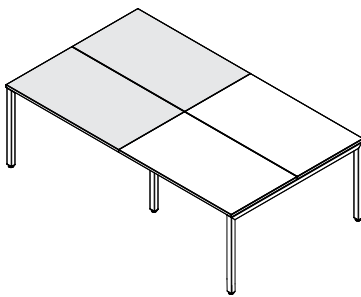

Workbench extended workstation, 4-leg  
Basic and additional module

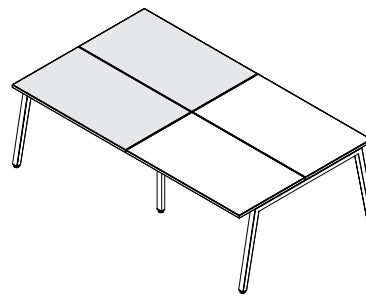

Workbench extended workstation, A-leg  
Basic and additional modules

### Table tops

Rectangular

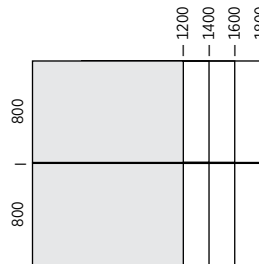
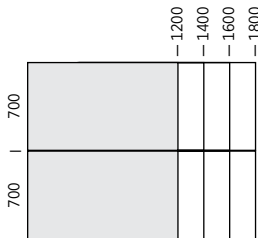

- 1 4-leg base
- 2 Workbench table top
- 3 Sliding release button
- 4 Horizontal wire trunking
- 5 Vertical wire trunking
- 6 Upper panel
- 7 Panel bracket

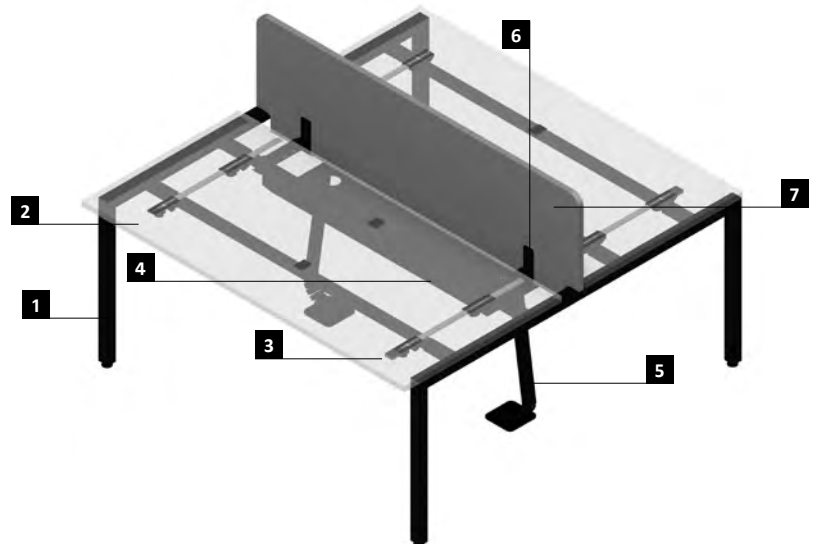

## 3. Desks with sideboard

### 3.1. Table top

– Fixed table tops

– Sliding table top (in range of 120 mm).

Both types of table tops are made of melamine faced chipboard (MFC), thickness 25 mm, with 2 mm edge in glue technology as standard, or laser edge as an option.

Available shapes: rectangular. Cut outs for grommets, rectangular outlets as well as media ports in various types and configurations – available as an option.

### 3.2. Base

#### 4-leg

Legs – “n-shape” welded legs, made of steel profile 50 × 40 mm:

– “n-shape” desk leg,

– short “n-shape” leg connecting table top with sideboard.

Frame – two beams made of steel profile 30 × 40 mm.

Construction – with 8 mm distance between table top and base.

#### A-leg

Legs – “A-shape” welded legs, made of steel profile 50 × 40 mm:

– “A-shape” desk leg,

– short “n-shape” leg connecting table top with sideboard.

Frame – two beams made of steel profile 30 × 40 mm.

Construction – with 8 mm distance between table top and base.

#### 4-leg wooden

Legs – “n-shape” legs, profile 50 × 40 mm:

– “n-shape” desk leg – upper part made of

welded steel profile, bottom part made of solid beech wood,

– short “n-shape” leg connecting table top with sideboard – made of steel profile.

Frame – two beams made of steel profile 30 × 40 mm.

Construction – with 8 mm distance between table top and base.

#### A-leg wooden

Legs – “A-shape” legs, profile 50 × 40 mm:

– “A-shape” desk leg – upper part made of

welded steel profile, bottom part made of solid beech wood,

– short “n-shape” leg connecting table top with sideboard – made of steel profile.

Frame – two beams made of steel profile 30 × 40 mm.

Construction – with 8 mm distance between table top and base.

#### Height

Fixed height:

– 750 mm (for construction with 8 mm distance between table top and base).

Levelling in range of 10 mm

#### Finish options

Metal legs:

– legs powder-coated in Traffic white (RAL 9016), Jet black (RAL 9005), White aluminium (RAL 9006), Slate grey (RAL 7015) or “Fashion Collection” colour,

– beams powder-coated only in Jet black (RAL 9005).

Wooden legs:

– metal elements powder-coated in Traffic white (RAL 9016), Jet black (RAL 9005), White aluminium (RAL 9006), Slate grey (RAL 7015) or “Fashion Collection” colour,

– wooden beech elements finished with transparent varnish (OC),

– beams powder-coated only in Jet black (RAL 9005).

– wooden beech elements finished with transparent varnish (OC),

– beams powder-coated only in Jet black (RAL 9005).

### 3.3. Sideboard

All elements are made of melamine faced chipboard (MFC), thickness 18 mm with edge in glue technology, except back – thickness 12 mm.

Back always in the same colour as carcass.

Carcass divided into following sections inside

– on the user's side: vertical partition wall

dividing the space into two parts, one with two shelves with levelling option,

– under table top: space with one shelf with levelling option.

Doors:

– 2 x sliding doors,

– perforated metal cover for one door as an option – made of metal sheet, thickness 1 mm. The cover has a decorative pattern

with round cut outs. Powder-coated in Traffic white (RAL 9016), Jet black (RAL 9005), White aluminium (RAL 9006), Slate grey (RAL 7015) or “Fashion Collection” colour.

– Traffic white (RAL 9016), Jet black (RAL 9005), White aluminium (RAL 9006), Slate grey (RAL 7015) or “Fashion Collection” colour.

Handles:

– CS5040 handle in the following colours: Traffic white (RAL 9016), Jet black (RAL 9005) or Matt Chrome,

– Easy Space handle in the following colours: Traffic white (RAL 9016), Slate grey (RAL 7015) Jet black (RAL 9005) or Alu

– SQart handle in Alu colour.

– Traffic white (RAL 9016), Slate grey (RAL 7015) Jet black (RAL 9005) or Alu

– SQart handle in Alu colour.

Base: 4 legs and beam made of 30 × 40 mm steel profile. Powder-coated in Traffic white (RAL 9016), Jet black (RAL 9005), White aluminium (RAL 9006), Slate grey (RAL 7015) or “Fashion Collection” colour. Base always in the same colour as the metal elements of desk legs.

Sideboard available in left or right version, equipped with cylinder lock or without lock.

– Width: 1400 mm

– Depth: 400 mm

– Fixed height 630 mm, levelling in range of 10 mm.

– Depth: 400 mm

– Fixed height 630 mm, levelling in range of 10 mm.

Distance between table top and sideboard top is 85 mm.

All desks are unassembled as standard, and sideboards are fully assembled.

## 3.4. Product range

### Desk bases with sideboards

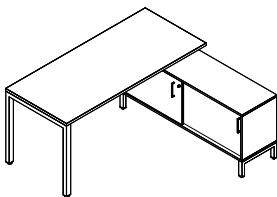

Desk 4-leg with sideboard  
Right version on the drawing

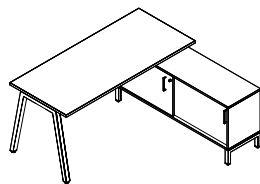

Desk A-leg with sideboard  
Right version on the drawing

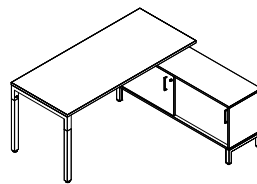

Desk 4-leg wooden with sideboard  
Right version on the drawing

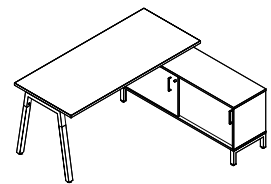

Desk A-leg wooden with sideboard  
Right version on the drawing

# Technical description

## Desk table tops with sideboard

### Rectangular

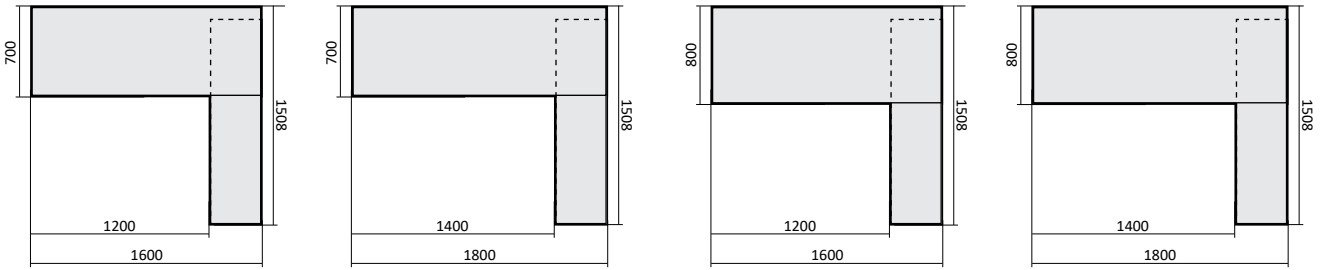

### Sideboard

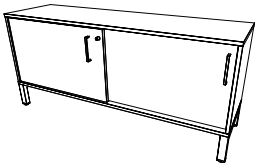

Sideboard  
Right version on the drawing

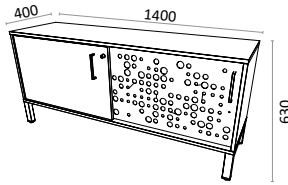

Sideboard with perforated metal cover  
Right version on the drawing

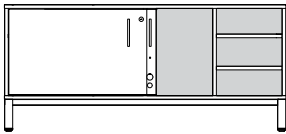

Sideboard – internal view  
Right version on the drawing

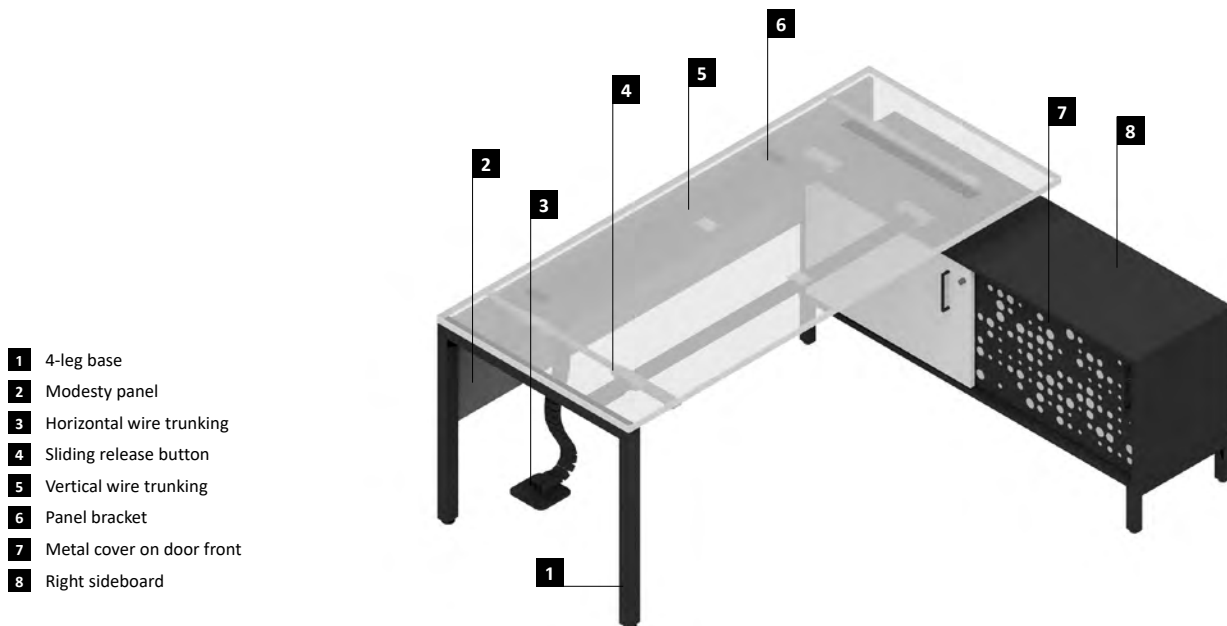
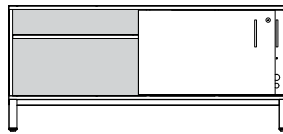

- 1 4-leg base
- 2 Modesty panel
- 3 Horizontal wire trunking
- 4 Sliding release button
- 5 Vertical wire trunking
- 6 Panel bracket
- 7 Metal cover on door front
- 8 Right sideboard

## 4. Workbenches with sideboards

– Two-seater workbench with sideboards (basic module) – face to face workstation, on two legs and two sideboards.

– Four-seater workbench with sideboards (basic module) – face to face workstation, on two central legs and four sideboards.

Central “n-shape” leg connecting table tops recessed 400 mm from table top edge.

Two-seater and four-seater workbenches with sideboards (basic modules) can be extended by using additional modules without sideboards.

### 4.1. Table tops

– Fixed table top

– Sliding table top (in range of 120 mm).

Both types of table tops are made of melamine faced chipboard (MFC), thickness 25 mm, with 2 mm edge in glue technology as standard, or laser edge as an option.

Available shape: rectangular.

Cut outs for grommets, rectangular outlets as well as media ports in various types and configurations – available as an option.

### 4.2. Bases

**Two-seater workbenches with sideboards (basic module):**

#### 4-leg

Legs – “n-shape” welded legs, made of steel profile 50 × 40 mm:

– “n-shape” workbench leg,

– two short “n-shape” legs connecting table tops with sideboards.

Frame – four beams made of steel profile 30 × 40 mm.

Construction – with 8 mm distance between table top and base.

#### A-leg

Legs – “A-shape” welded legs, made of steel profile 50 × 40 mm:

– “A-shape” workbench leg,

– two short “n-shape” legs connecting table tops with sideboards.

Frame – four beams made of steel profile 30 × 40 mm.

Construction – with 8 mm distance between table top and base.

#### 4-leg wooden

Legs – “n-shape” legs, profile 50 × 40 mm:

– “n-shape” workbench leg – upper part made of welded steel profile, bottom part made of solid beech wood,

– two short “n-shape” legs connecting table tops with sideboards – made of steel profile.

Frame – four beams made of steel profile 30 × 40 mm.

Construction – with 8 mm distance between table top and base.

#### A-leg wooden

Legs – “A-shape” legs, profile 50 × 40 mm:

– “A-shape” workbench leg – upper part made of welded steel profile, bottom part made of solid beech wood,

– two short “n-shape” legs connecting table tops with sideboards – made of steel profile.

Frame – four beams made of steel profile 30 × 40 mm.

Construction – with 8 mm distance between table top and base.

**Four-seater workbenches with sideboards (basic module):**

#### Metal legs

Legs – “n-shape” welded legs, made of steel profile 50 × 40 mm:

– central “n-shape” workbench leg recessed 400 mm from table top edge,

– four short “n-shape” legs connecting table tops with sideboards.

Frame – eight beams made of steel profile 30 × 40 mm.

Construction – with 8 mm distance between table top and base.

#### Wooden legs

Legs – “n-shape” legs, profile 50 × 40 mm:

– central “n-shape” workbench leg – upper part made of welded steel profile, bottom part made of solid beech wood, recessed 400 mm from table top edge,

– four short “n-shape” legs connecting table tops with sideboards – made of steel profile.

Frame – eight beams made of steel profile 30 × 40 mm.

Construction – with 8 mm distance between table top and base.

#### Height

Fixed height:

– 750 mm (for construction with 8 mm distance between table top and base).

Levelling in range of 10 mm

#### Finish option

Metal legs:

– legs powder-coated in Traffic white (RAL 9016), Jet black (RAL 9005), White aluminium (RAL 9006), Slate grey (RAL 7015) or “Fashion Collection” colour,

– beams always powder-coated in Jet black (RAL 9005).

Wooden legs:

– metal elements powder-coated in Traffic white (RAL 9016), Jet black (RAL 9005), White aluminium (RAL 9006), Slate grey (RAL 7015) or “Fashion Collection” colour,

– wooden beech elements finished with transparent varnish (OC).

– beams always powder-coated in Jet black (RAL 9005).

Both workbench with sideboards modules are available with or without possibility of panel integration. Regardless of selected option (with or without panel) total depth remains 1400 mm or 1600 mm.

### 4.3. Sideboard

All elements are made of melamine faced chipboard (MFC), thickness 18 mm with edge in glue technology, except back – thickness 12 mm. Back always in the same colour as carcass.

Carcass divided into following sections inside:

– on the user’s side: vertical partition wall dividing the space into two parts, one with two shelves with levelling option,

– under table top: space with one shelf with levelling option.

Doors:

– 2 x sliding doors,

– perforated metal cover for one door as an option – made of metal sheet, thickness 1 mm. The cover has a decorative pattern with round cut outs.

Powder-coated in Traffic white (RAL 9016), Jet black (RAL 9005), White aluminium (RAL 9006), Slate grey (RAL 7015) or “Fashion Collection” colour.

Handles:

– CS5040 handle in the following colours: Traffic white (RAL 9016), Jet black (RAL 9005) or Matt Chrome,

– Easy Space handle in the following colours: Traffic white (RAL 9016), Slate grey (RAL 7015)

Jet black (RAL 9005) or Alu

– SQuart handle in Alu colour.

Base: 4 legs and beam made of 30 × 40 mm steel profile. Powder-coated in Traffic white (RAL 9016), Jet black (RAL 9005), White aluminium (RAL 9006), Slate grey (RAL 7015) or “Fashion Collection” colour. Base always in the same colour as the metal elements of workbench legs.

Sideboard available in left or right version, equipped with cylinder lock or without lock.

– Width: 1400 mm

– Depth: 400 mm

– Fixed height 630 mm, levelling in range of 10 mm.

Distance between table top and sideboard top is 85 mm.

All workbenches are unassembled as standard, and sideboards are fully assembled.

# Technical description

## 4.4. Product range

### Workbench bases with sideboards

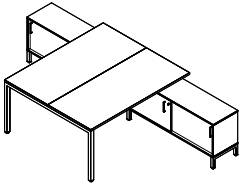

Two-seater workbench, 4-leg with sideboards (basic module)

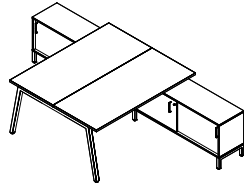

Two-seater workbench, A-leg with sideboards (basic module)

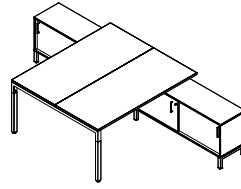

Two-seater workbench, 4-leg wooden with sideboards (basic module)

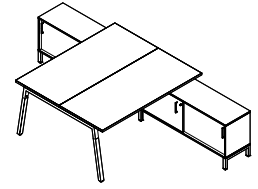

Two-seater workbench, A-leg wooden with sideboards (basic module)

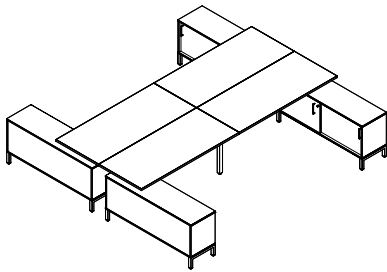

Four-seater workbench, metal legs with sideboards (basic module)

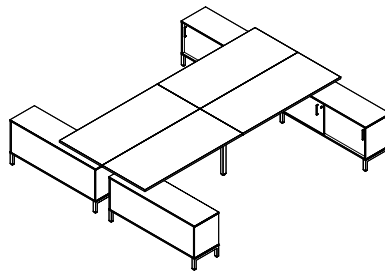

Four-seater workbench, wooden legs with sideboards (basic module)

### Table tops for workbenches with sideboards

#### Rectangular

##### Two-seater workbench

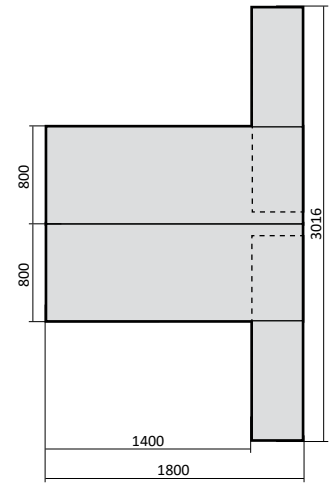
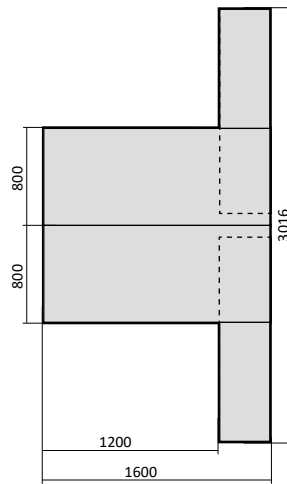
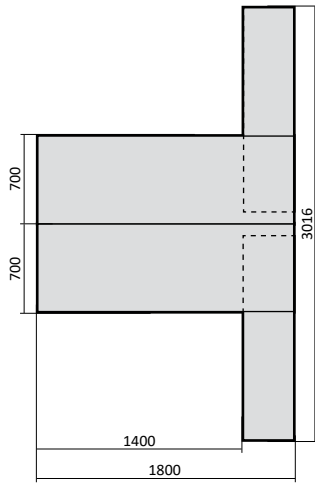
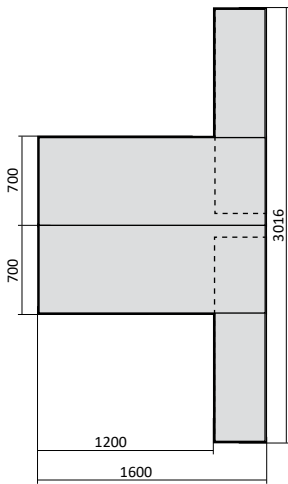

##### Four-seater workbench

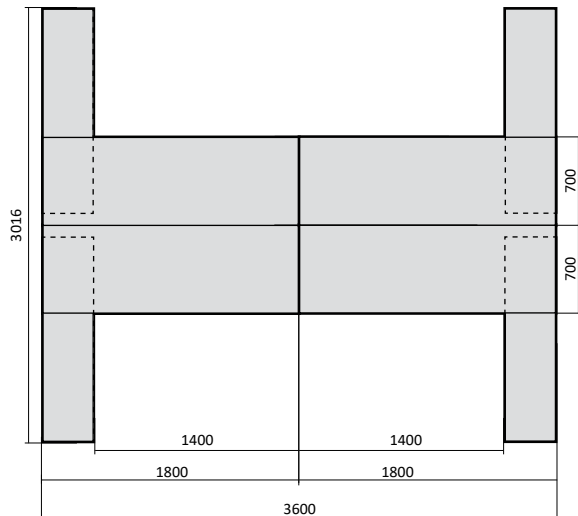
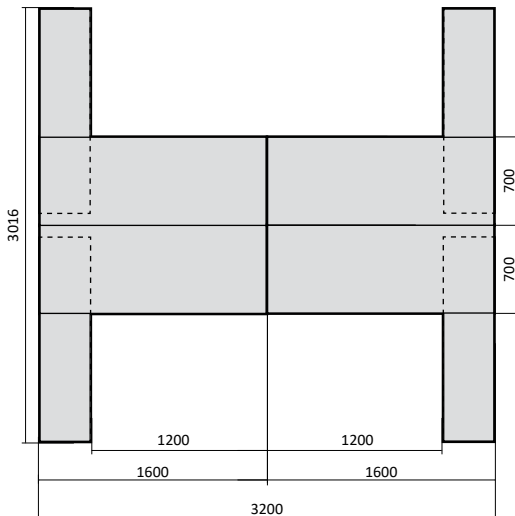

# Technical description

CS5040

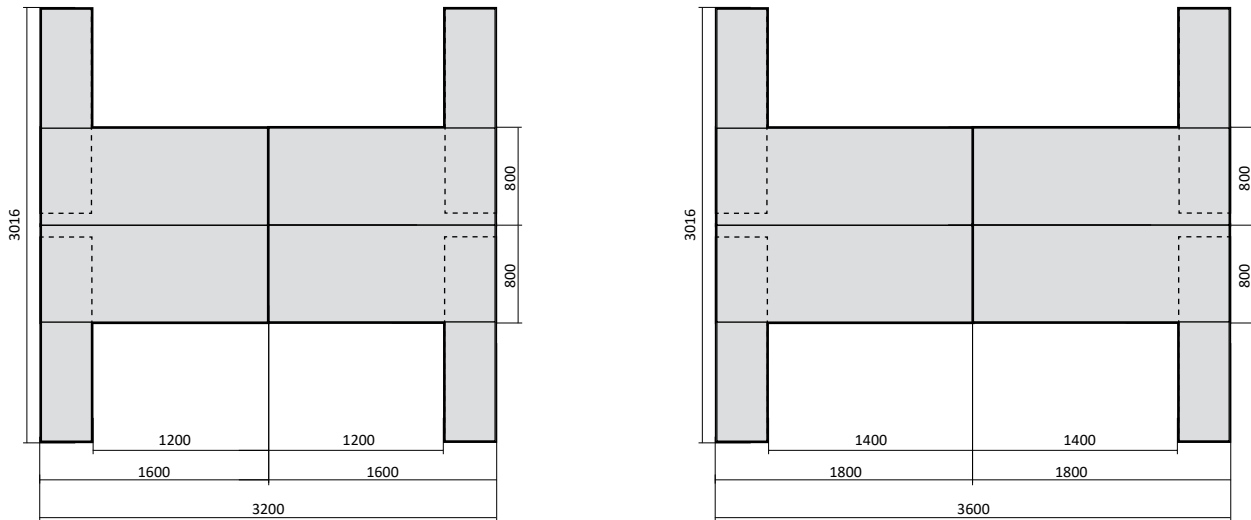

## Sideboard

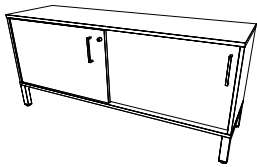

Sideboard  
Right version on the drawing

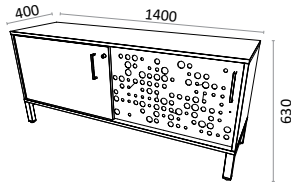

Sideboard with perforated metal cover  
Right version on the drawing

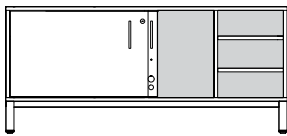

Sideboard – internal view  
Right version on the drawing

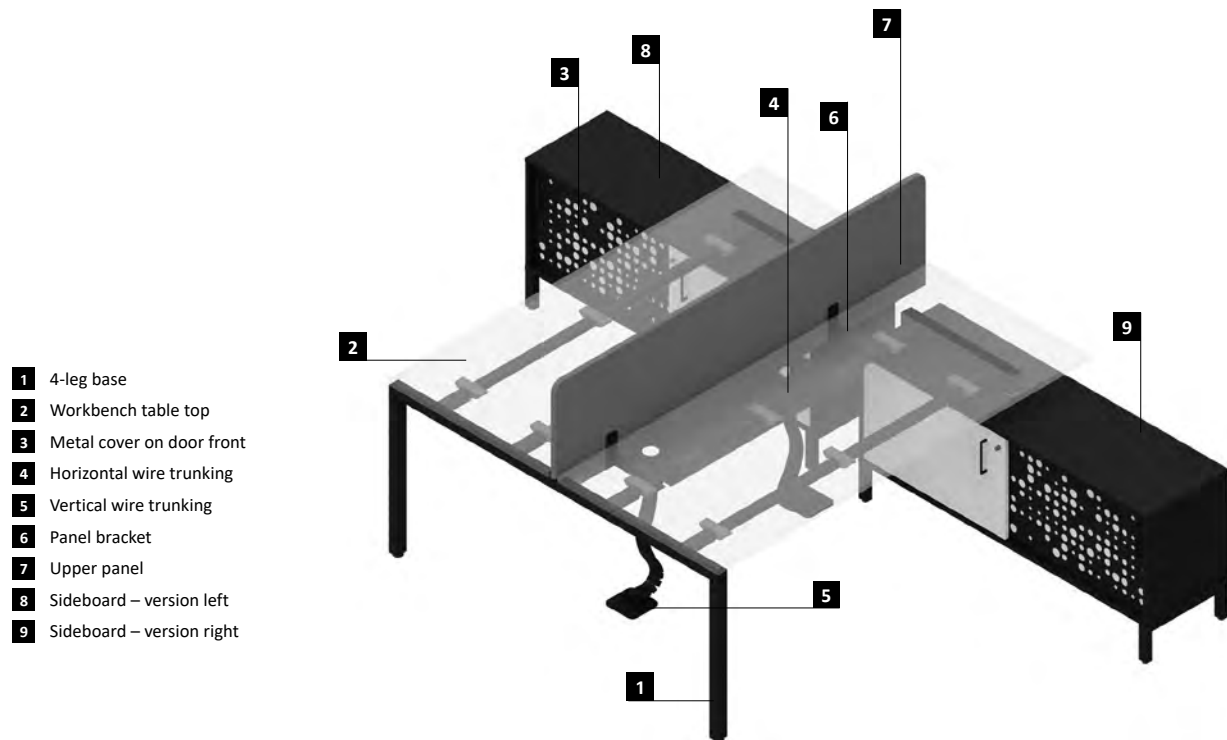
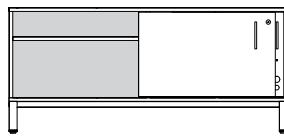

- 1 4-leg base
- 2 Workbench table top
- 3 Metal cover on door front
- 4 Horizontal wire trunking
- 5 Vertical wire trunking
- 6 Panel bracket
- 7 Upper panel
- 8 Sideboard – version left
- 9 Sideboard – version right

# Technical description

## 5. Conference tables

### 5.1. Table top

Fixed table tops – made of:

- melamine faced chipboard (MFC), thickness 25 mm, with 2 mm edge in glue technology as standard, or laser edge as an option. Rectangular table top shape in following dimensions: widths 1200, 2200, 2800, 3600 mm, and depth 1200 mm. Cut outs for grommets as well as media ports in various types and configurations – available as an option,
- Fenix NTM – upper part of chipboard covered with Fenix NTM laminate, bottom part covered with anti-resilient laminate in gray colour, thickness 25 mm, 1 mm laser edge in the same colour as table top.

### 5.2. Base

#### 4-leg

Legs – “n-shape” welded legs, made of steel profile 50 × 40 mm.

Frame – beams made of steel profile 30 × 40 mm.

Construction – with 8 mm distance between table top and base.

#### A-leg

Legs – “A-shape” welded legs, made of steel profile 50 × 40 mm.

Frame – beams made of steel profile 30 × 40 mm.

Construction – with 8 mm distance between table top and base.

#### 4-leg wooden

Legs – “n-shape” legs, profile 50 × 40 mm, upper part made of welded steel profile, bottom part made of solid beech wood.

Frame – two beams made of steel profile 30 × 40 mm.

Construction – with 8 mm distance between table top and base.

#### A-leg wooden

Legs – “A-shape” legs, profile 50 × 40 mm, upper part made of welded steel profile, bottom part made of solid beech wood.

Frame – two beams made of steel profile 30 × 40 mm.

Construction – with 8 mm distance between table top and base.

### Height

Fixed height:

- 750 mm (for construction with 8 mm distance between table top and base).
- Levelling in range of 10 mm.

### Finish option

Metal legs:

- legs powder-coated in Traffic white (RAL 9016), Jet black (RAL 9005), White aluminium (RAL 9006), Slate grey (RAL 7015) or “Fashion Collection” colour,
- beams powder-coated only in Jet black (RAL 9005).

Wooden legs:

- metal elements powder-coated in Traffic white (RAL 9016), Jet black (RAL 9005), White aluminium (RAL 9006), Slate grey (RAL 7015) or “Fashion Collection” colour,
- wooden beech elements finished with transparent varnish (0C),
- beams powder-coated only in Jet black (RAL 9005).

Conference tables with two-piece table tops, dimensions 2800 × 1200 mm and 3600 × 1200 mm, are equipped with additional “n-shape” welded leg, recessed 400 mm from table top edge.

All conference tables are unassembled as standard.

### 5.3. Product range

#### Bases

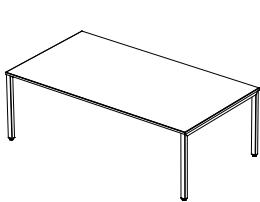

4-leg

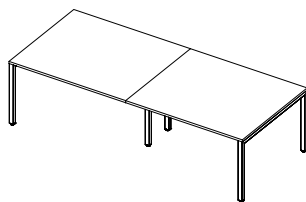

4-leg wooden

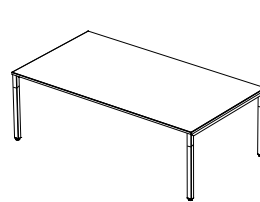

A-leg

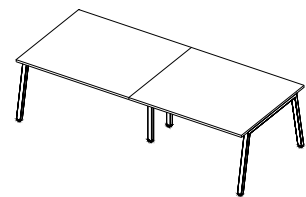

A-leg wooden

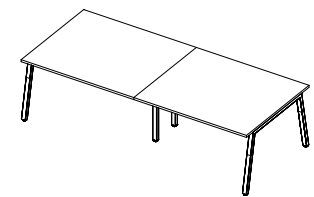
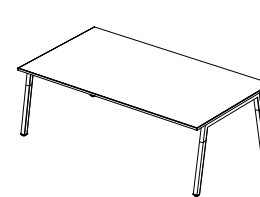

#### Table tops

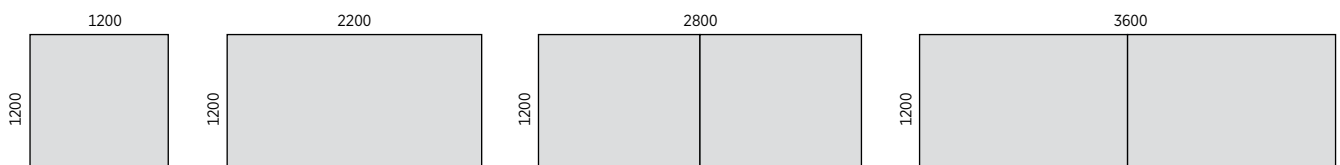

## 6. High meeting tables

### 6.1. Table top

**Fixed table tops** – made of:

- melamine faced chipboard (MFC), thickness 25 mm, with 2 mm edge in glue technology as standard, or laser edge as an option. Rectangular table top shape in following dimensions: 1400 × 900, 1800 × 900, 1400 × 1000, 2000 × 1000 mm. Cut outs for grommets as well as media ports in various types and configurations – available as an option,
- Fenix NTM – upper part of chipboard covered with Fenix NTM laminate, bottom part covered with anti-resilient laminate in grey colour, thickness 25 mm, 1 mm laser edge in the same colour as table top.

### 6.2. Base

#### 4-leg

**Legs** – “n-shape” welded legs, made of steel profile 50 × 40 mm with steel linking element (crossbar) to assemble foot bar.

**Foot bar** – two beams made of steel profile 30 × 40 mm to be assembled with legs linking elements.

**Frame** – two beams made of steel profile 30 × 40 mm.

**Construction** – with 8 mm distance between table top and base.

#### A-leg

**Legs** – “A-shape” welded legs, made of steel profile 50 × 40 mm with steel linking element (crossbar) to assemble foot bar.

**Foot bar** – two beams made of steel profile 30 × 40 mm to be assembled with legs linking elements.

**Frame** – two beams made of steel profile 30 × 40 mm.

**Construction** – with 8 mm distance between table top and base.

#### 4-leg wooden

**Legs** – “n-shape” legs, profile 50 × 40 mm, upper part made of welded steel profile, bottom part made of solid beech wood with steel linking element (crossbar) to assemble foot bar.

**Foot bar** – two beams made of steel profile 30 × 40 mm, assembly to an element connecting legs.

**Frame** – two beams made of steel profile 30 × 40 mm.

**Construction** – with 8 mm distance between table top and base.

#### A-leg wooden

**Legs** – “A-shape” legs, profile 50 × 40 mm, upper part made of welded steel profile, bottom part made of solid beech wood with steel linking element (crossbar) to assemble foot bar.

**Foot bar** – two beams made of steel profile 30 × 40 mm, assembly to an element connecting legs.

**Frame** – two beams made of steel profile 30 × 40 mm.

**Construction** – with 8 mm distance between table top and base.

### Height

**Fixed height:**

- 1060 mm (for construction with 8 mm distance between table top and base).
- Levelling in range of 10 mm.

### Finish option

**Metal legs:**

- legs, beams and foot bar powder-coated in Traffic white (RAL 9016), Jet black (RAL 9005), White aluminium (RAL 9006), Slate grey (RAL 7015) or “Fashion Collection” colour.

**Wooden legs:**

- metal elements of legs, beams and foot bar powder-coated in Traffic white (RAL 9016), Jet black (RAL 9005), White aluminium (RAL 9006), Slate grey (RAL 7015) or “Fashion Collection” colour,
- wooden beech elements finished with transparent varnish (OC).

All metal elements always in the same colour. All high meeting tables are unassembled as standard.

## 6.3. Product range

### Bases

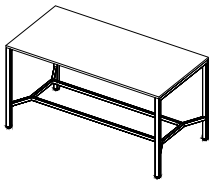

4-leg

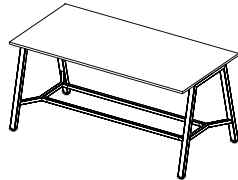

A-leg

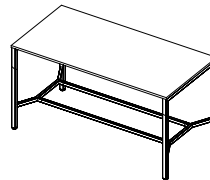

4-legs wooden

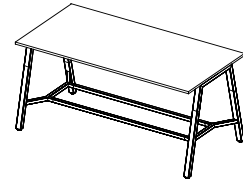

A-legs wooden

### Table tops

Rectangular

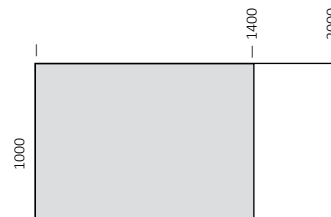
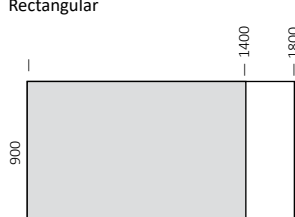



## 7.1. Available colours for desks and edges with wooden legs

		Table top finish – melamine											
		BI	BZ	CC	MB	MP	MS	NM	NS	NR	NK	MK	
Edge finish – ABS	Laser	BI	○	○	○	○	○	○	○	○	○	○	
		MB	○	○	○	○	○	○	○	○	○	○	
		MP	○	○	○	○	○	○	○	○	○	○	
	2 mm glue technology	BI	○	○	○	○	○	○	○	○	○	○	
		BZ	○	○	○	○	○	○	○	○	○	○	
		MB	○	○	○	○	○	○	○	○	○	○	
		MP	○	○	○	○	○	○	○	○	○	○	
		CC	○	○	○	○	○	○	○	○	○	○	
		MS	○	○	○	○	○	○	○	○	○	○	
		NM	○	○	○	○	○	○	○	○	○	○	
		NS	○	○	○	○	○	○	○	○	○	○	
		NR	○	○	○	○	○	○	○	○	○	○	
		NK	○	○	○	○	○	○	○	○	○	○	
		MK											○

## 8. Grommets and media ports

**Grommet** – made of plastic in aluminium (AU), white (W) or black (B) colour. Dedicated to all types of desks, desks with sideboard, workbenches, workbenches with sideboards, conference tables and high meeting tables.

Grommet dimensions: 90 × 90 mm.

Cut out dimensions: Ø 80 mm.

Available positioning for:

- desks, desks with sideboards, workbenches, workbenches with sideboards: left, middle or right (placed 90 mm from table top edge),

- high meeting tables: central,
- conference tables: central left and central right or central.

**Rectangular outlet with brush** – made of aluminium powder-coated in aluminium (AL), white (WH) or black (BL) colour. Dedicated to desks, desks with sideboards, workbenches and workbenches with sideboards, for fixed table tops only.

Outlet dimensions: 300 × 130 mm.

Cut out dimensions: 280 × 110 mm.

Available positioning:

- desks and workbenches with sideboards: left, central or right position (placed 320 mm from table top edge),
- desks with sideboards and workbenches with sideboards: central position.

**Media ports** – available in various types and configurations, to be ordered separately, according to [availability matrix](#), see price list.

**Note:** more details in grommets and media ports [positioning matrix](#).





# Technical description

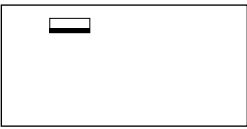
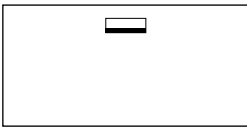
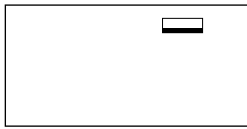
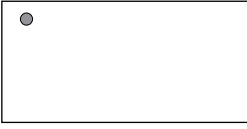
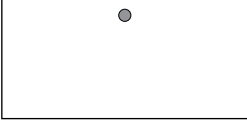

## Grommets and media ports for desks and workbenches

Metal rectangular cable outlet and media ports available only for fixed table top.

- ③ – Metal elements finish:  
 White (WH)  
 Aluminium (AL)  
 Black (BL)
- ④ – Plastic elements finish:  
 White (W)  
 Aluminium (AU)  
 Black (B)

		Rectangular cut out for: metal cable outlet with brush – included (QE)		
		Left	Middle	Right
				
		QE-③/0/0	0/QE-③/0	0/0/QE-③
Ø 80 mm cut out for: grommet – included (QC) or dedicated media ports: Powerdot*, miniBatt Fr80 wireless charger	Left		/	/
		QC-④/0/0		
	Middle			
		0/QC-④/0*		
Right		/	/	
	0/0/QC-④			
Left and right				
	QC-④/0/QC-④			

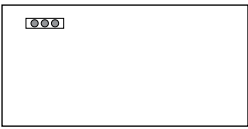
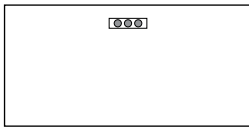
\* Depth adjustment only in 2 levels.

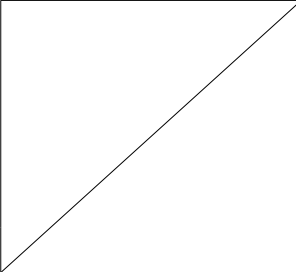
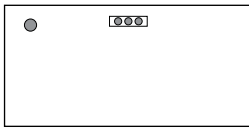
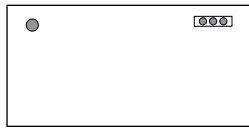
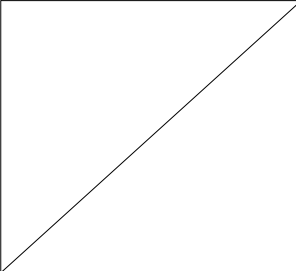
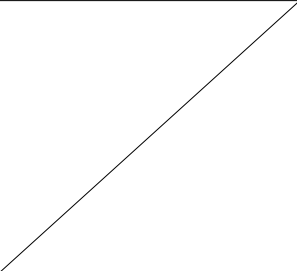
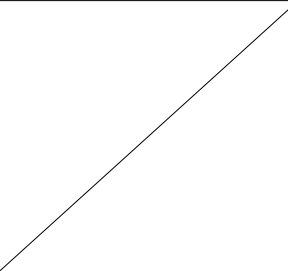
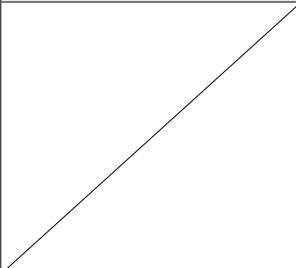
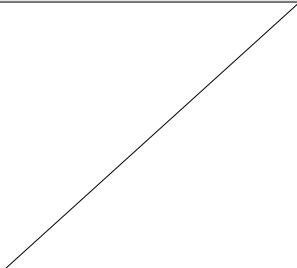
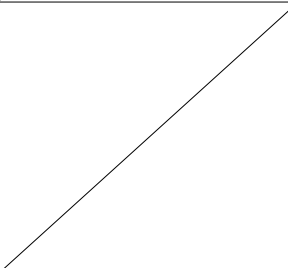
Rectangular cut out for media port Power Frame 3M (MP1)		
Left	Middle	Right
		
MP1/0/0	0/MP1/0	0/0/MP1
		
	QC-4/MP1/0	QC-4/0/MP1
		
MP1/0/QC-4	0/MP1/QC-4	
		

Examples of grommets, rectangular outlets and media ports positioning in workbenches table tops.  
**NOTE:** each presented positioning always from the user's side.

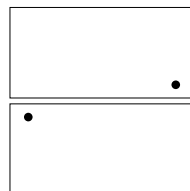

left position

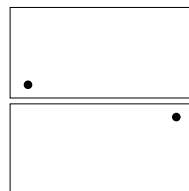

right position

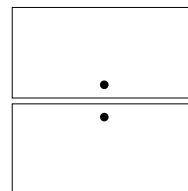

central position

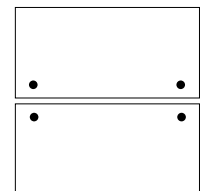

left and right position

# Technical description

## Grommets and media ports for desks and workbenches with sideboards

Metal rectangular cable outlet and media ports available only for fixed table top.

- ③ – Metal elements finish:
  - White (WH)
  - Aluminium (AL)
  - Black (BL)
- ④ – Plastic elements finish:
  - White (W)
  - Aluminium (AU)
  - Black (B)

		Rectangular cut out for: metal cable outlet with brush – included (QE)	Rectangular cut out for media port Power Frame 3M (MP1)
		Middle	
		0/QE-③/0	0/MP1/0
Ø 80 mm cut out for: grommet – included (QC) or dedicated media ports: Powerdot*, miniBatt FR80 wireless charger	Left		
		QC-④/0/0	QC-④/MP1/0
	Middle		
		0/QC-④/0	
Right			
	0/0/QC-④	0/MP1/QC-④	
Left and right			
	QC-④/0/QC-④		

\* Depth adjustment only in 2 levels.

Positioning of sideboard doesn't affect the positioning of grommets and media ports on table top

Examples of grommets, rectangular outlets and media ports positioning in workbenches table tops.

**NOTE:** each presented positioning always from the user's side.

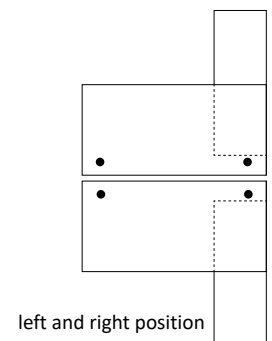
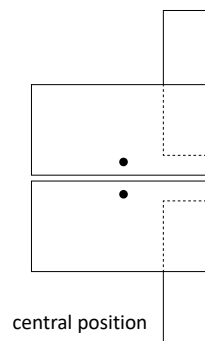
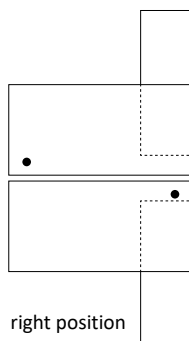
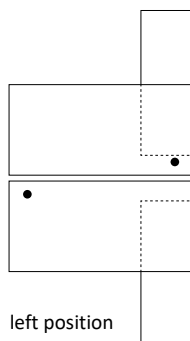

## Grommets and media ports for 4-seater workbench with sideboards

Metal rectangular cable outlet and media ports available only for fixed table top.

- ③ – Metal elements finish:
  - White (WH)
  - Aluminium (AL)
  - Black (BL)
- ④ – Plastic elements finish:
  - White (W)
  - Aluminium (AU)
  - Black (B)

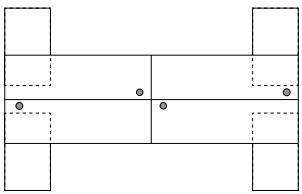
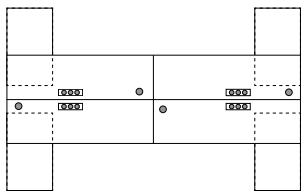
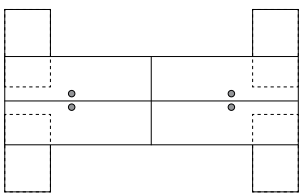
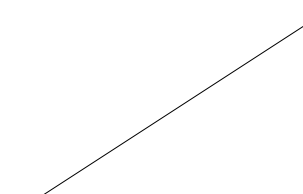
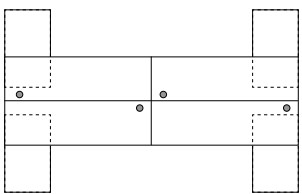
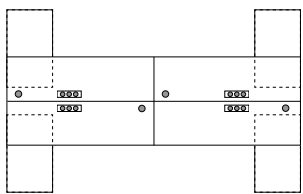
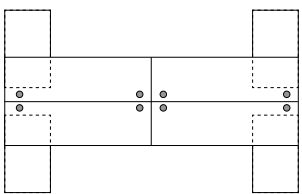
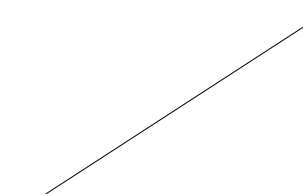
		Middle	
		Rectangular cut out for: metal cable outlet with brush – included (QE)	Rectangular cut out for media port Power Frame 3M (MP1)
Ø 80 mm cut out for: grommet – included (QC) or dedicated media ports: Powerdot*, miniBatt FR80 wireless charger	Left		
		0/QE-③/0	0/MP1/0
	Middle		
		0/QC-④/0	QC-④/MP1/0
Right			
	0/0/QC-④	0/MP1/QC-④	
Left and right			
	QC-④/0/QC-④		





\* Depth adjustment only in 2 levels.

Positioning of sideboard doesn't affect the positioning of grommets and media ports on table top

# Technical description

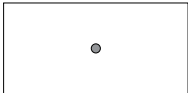
## Grommets and media ports for high meeting tables and conference tables

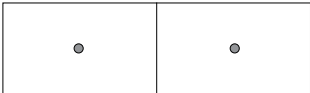
- ④ – Plastic elements finish:  
 White (W)  
 Aluminium (AU)  
 Black (B)

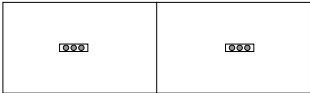
	High meeting tables	Conference tables			
W	All sizes	1200	2200	2800	3600
D		1200			
Position		Central	Central left and central right	Central left and central right	
dedicated media ports: Powerdot, miniBatt FR80 wireless charger					
		0/QC-④/0	QC-④/0/QC-④	QC-④/0/QC-④	
Rectangular cut out for media port Power Frame 3M (MP1)			/		
		0/MP1/0		MP1/0/MP1	

## 9. Panels

CS5040 system is accessorized with upper panels fully upholstered or made of thermoformed PET felt with acoustic properties.

Panel is easily placed in U-shape bracket which is connected with basic bracket directly fixed to desk frame. Set of basic brackets allows for fixing upper panel, modesty panel and horizontal wire trunking simultaneously. This unique connection system has been claimed as industrial design. **Basic bracket** – metal fixing element used for assembly upper panel, modesty panel and horizontal wire trunking (separately or according to [matrix combinations](#) to desk frame. Basic brackets provide the following adjustment options:

- upper panels: depth adjustment in range of 20 mm, vertical alignment,
- modesty panels: height adjustment, vertical alignment.

Brackets finish options: powder-coated in Traffic white (RAL 9016), Jet black (RAL 9005), White aluminium (RAL 9006), Slate grey (RAL 7015). Basic brackets to be ordered separately always as a set of 2 pcs.

### 9.1. Desk panels

#### Fixing with basic brackets

**Upper fully upholstered, front** (model 1) – structure is made of 8 mm raw chipboard with 8 mm soft fibreboard on both sides, with fabric cover, pinnable. Panel thickness 24 mm, upper edges rounded at 50 mm radius, equipped with dedicated brackets for fixing with basic brackets. Brackets finish options: powder-coated in Traffic white (RAL 9016), Jet black (RAL 9005), White aluminium (RAL 9006), Slate grey (RAL 7015) or “Fashion Collection” colours. **Upper felt, front** (model 1) – made of thermoformed felt in light or dark grey colour. Panel thickness 24 mm, upper edges rounded at 40 mm radius, equipped with dedicated brackets for fixing with basic brackets.

Brackets finish options: powder-coated in Traffic white (RAL 9016), Jet black (RAL 9005), White aluminium (RAL 9006), Slate grey (RAL 7015) or “Fashion Collection” colour.

**Note:** it is possible to use upper panel (model 1) shorter than desk width but in case of adding horizontal wire trunking it has to be the same size as panel.

**Modesty, front** – made of melamine faced chipboard (MFC), thickness 18 mm, with edge in glue technology. Panel is equipped with a set of brackets.

**Note:** it is possible to assemble modesty panel using basic brackets or without basic brackets directly to fixed table top ([see matrix combinations](#)).

#### Fixing without basic brackets directly to desk frame

Panels for CS5040 desks with fixed table top, and Play&Work desks with U-shape base.

**Upper fully upholstered, front** (model 2) – structure is made of 8 mm raw chipboard with 8 mm soft fibreboard on both sides, with fabric cover, pinnable. Panel thickness 24 mm, upper edges rounded at 50 mm radius, equipped with dedicated brackets for fixing directly to desk frame with fixed table top only.

Brackets finish options: powder-coated in Traffic white (RAL 9016), Jet black (RAL 9005), White aluminium (RAL 9006), Slate grey (RAL 7015).

**Upper felt, front** (model 2) – made of thermoformed felt in light or dark grey color. Panel thickness 24 mm, upper edges rounded at 40 mm radius, equipped with dedicated brackets for fixing directly to desk frame with fixed table top only.

Brackets finish options: powder-coated in Traffic white (RAL 9016), Jet black (RAL 9005), White aluminium (RAL 9006), Slate grey (RAL 7015).

**Note:** in CS5040 desk it is not possible to assemble upper panel (model 2) without using basic brackets and modesty panel simultaneously ([see matrix combinations](#)).

### 9.2. Panels for desks with sideboards

#### Fixing with basic brackets

**Upper upholstered, front** (model 1) – structure is made of 8 mm raw chipboard covered with 8 mm soft fibreboard on both sides, with fabric cover, pinnable. Panel thickness 24 mm, upper edges rounded at 50 mm radius, equipped with dedicated brackets for fixing with basic brackets. Brackets finish options: powder-coated in Traffic white (RAL 9016), Jet black (RAL 9005), White aluminium (RAL 9006), Slate grey (RAL 7015) or “Fashion Collection” colour.

**Upper felt, front** (model 1) – made of thermoformed felt in light or dark grey colour. Panel thickness 24 mm, upper edges rounded at 40 mm radius, equipped with dedicated brackets for fixing with basic brackets.

Brackets finish options: powder-coated in Traffic white (RAL 9016), Jet black (RAL 9005), White aluminium (RAL 9006), Slate grey (RAL 7015).

**Modesty, front** – made of melamine faced chipboard (MFC), thickness 18 mm, with edge in glue technology. Panel is equipped with a set of brackets.

Available in left or right version.

**Note:** it is possible to assemble modesty panel without basic brackets directly to fixed table top. In case of adding horizontal wire trunking, modesty panel also needs to be assembled directly to table top.

### 9.3. Workbench panels

**Upper fully upholstered, front** – structure is made of 8 mm raw chipboard with 8 mm soft fibreboard on both sides, with fabric cover, pinnable. Panel thickness 24 mm, upper edges rounded at 50 mm radius. Panel is already equipped with all necessary fixing brackets. Brackets finish options: powder-coated in Traffic white (RAL 9016), Jet black (RAL 9005), White aluminium (RAL 9006), Slate grey (RAL 7015) or “Fashion Collection” colours.

### 9.4. Panels for workbenches with sideboards

**Upper upholstered, front** – structure is made of 8 mm raw chipboard with 8 mm soft fibreboard on both sides, with fabric cover, pinnable. Panel thickness 24 mm, upper edges rounded at 50 mm radius. Panel has a one-sided undercut and is already equipped with all necessary fixing brackets.

Brackets finish options: powder-coated in Traffic white (RAL 9016), Jet black (RAL 9005), White aluminium (RAL 9006), Slate grey (RAL 7015) or “Fashion Collection” colours.

### 9.5. Organiser strip for CS5040 panel

Organiser strip pulled over upper edge of upholstered upper panels, dedicated for desks, desks with sideboards, workbenches, workbenches with sideboards. Made of two metal rods, Ø 10 mm connected with fixing brackets, made of metal sheet, thickness 4 mm. Dedicated accessories for panel organiser strip to be ordered separately.

#### Finish options

- powder-coated in Traffic white (RAL 9016), Jet black (RAL 9005), White aluminium (RAL 9006), Slate grey (RAL 7015) or “Fashion Collection” colour.

# Technical description

CS5040

## 9.6. Product range

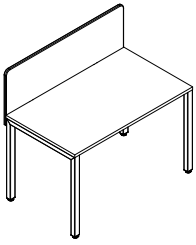

Desk panel, upper fully upholstered, front

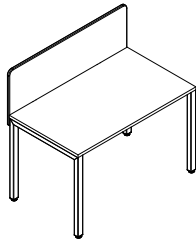

Desk panel, upper felt, front

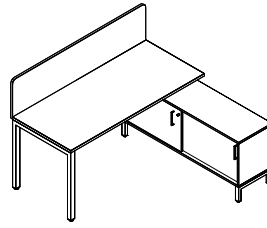

Upper fully upholstered, front panel for desk with sideboard

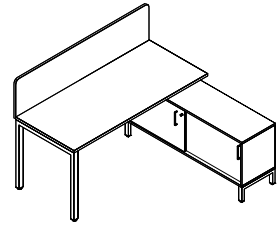

Desk panel, upper felt, front desk with sideboard

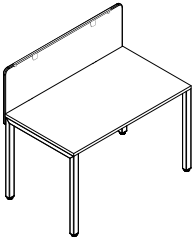

Desk panel, upper front with organiser strip

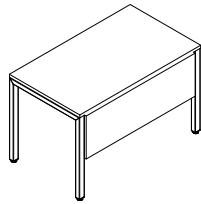

Desk panel, modesty, front

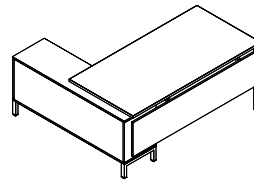

Modesty, front panel for desk with sideboard

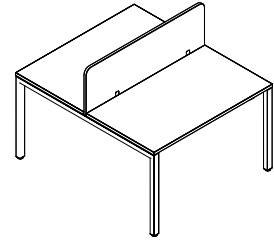

Workbench panel, upper fully upholstered, front

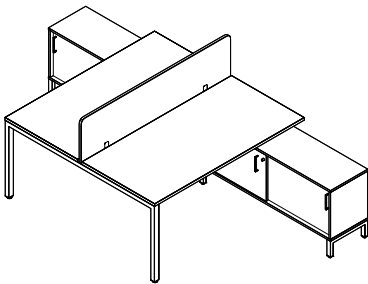

Upper fully upholstered, front panel for two-seater workbench with sideboards

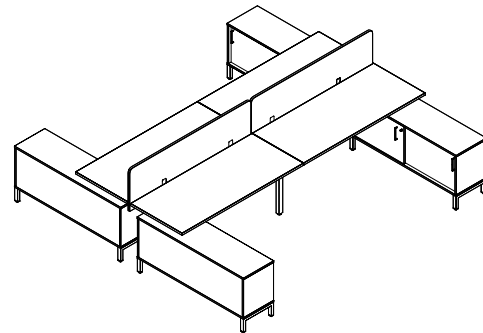

Upper fully upholstered, front panel for four-seater workbench with sideboards

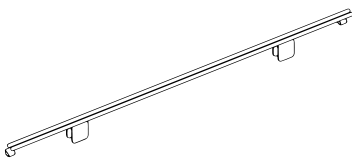

Organiser strip for upper, front panels



CS5040 panel for desk and desk with sideboard – fixing with basic brackets (model 1)



CS5040 panel for desk – fixing without basic brackets, directly to desk frame (model 2)

## 10. Cable management

**Horizontal wire trunking – foldable** – made of steel sheet, thickness 1.0 mm, with cut outs that allow to integrate it with vertical wire trunking – modular. Wire trunking is already equipped with plastic brackets.

Assembly possibilities (see matrix combinations).

- by using basic brackets (desks, desks with sideboards),
- without basic brackets directly to fixed table tops only (desks, desks with sideboards, conference tables, and high meeting tables).

Finish options: powder-coated in Traffic white (RAL 9016), Jet black (RAL 9005), White aluminium (RAL 9006), Slate grey (RAL 7015).

**Horizontal wire trunking – shared** – made of steel sheet, thickness 1.0 mm with cut outs on both sides that allow to integrate it with vertical wire trunking – modular.

Assembly possibilities:

- tool-free assembly to table top frame (workbenches, workbenches with sideboards and conference tables).

Finish options: powder-coated in Traffic white (RAL 9016), Jet black (RAL 9005), White aluminium (RAL 9006), Slate grey (RAL 7015).

**Vertical wire trunking – modular** – made of plastic in aluminium, white or black colour. Fixing to horizontal wire trunking or directly to fixed table tops for desks, desks with sideboards, workbenches, workbenches with sideboards and conference tables.

**Vertical wire trunking – flexible spring** – made of plastic in aluminium, black or transparent colour. Fixing directly to table top for desks, desks with sideboards, workbenches, workbenches with sideboards, high meeting tables and conference tables.

## 11. Orga Tower, free-standing

### 11.1. Orga Tower

All elements are made of melamine faced chipboard (MFC), thickness 18 mm, with edge in glue technology.

High drawer divided into following sections inside:

- organizer shelf in upper part, depth: 80 mm (additional felt organizer to be ordered separately),
- vertical partition wall dividing the space into two parts, each has a shelf with levelling option.

Handles:

Drawers opening by 15 mm gap between drawer front and carcass (no handles) as standard,

- CS5040 handle in the following colours: Traffic white (RAL 9016), Jet black (RAL 9005) or Matt Chrome as an option:

- Easy Space handle in the following colours: Traffic white (RAL 9016), Slate grey (RAL 7015) Jet black (RAL 9005) or Alu as an option.
- SQart handle in Alu colour as an option.

Orga Tower is available in left or right drawer version, and equipped with cylinder lock. Additional castor and counter-weight included as standard for safety reasons.

Fixed height: 950 mm, levelling in range of 10 mm.

Orga Tower – fully assembled as standard.

### 11.2. Orga Tower with front cover

All elements are made of melamine faced chipboard (MFC), thickness 18 mm, with edge in glue technology.

Perforated metal cover for drawer front.

Made of metal sheet, thickness 1 mm. The cover has a decorative pattern with round cut outs.

High drawer divided into following sections inside:

- organizer shelf in upper part, depth: 80 mm (additional felt organizer to be ordered separately),
- vertical partition wall dividing the space into two parts, each has a shelf with levelling option. This space is equipped with a sliding cover, made of perforated metal sheet, thickness 1 mm. The cover has a decorative pattern with round cut outs and is always in the same colour as the cover on the drawer front.

Handles:

- drawers opening by 15 mm gap between drawer front and carcass (no handles) as standard,
- CS5040 handle in the following colours: Traffic white (RAL 9016), Jet black (RAL 9005) or Matt Chrome as an option:
- Easy Space handle in the following colours: Traffic white (RAL 9016), Slate grey (RAL 7015) Jet black (RAL 9005) or Alu as an option.
- SQart handle in Alu colour as an option.

Finish options for perforated metal elements.

- powder-coated in Traffic white (RAL 9016), Slate grey (RAL 7015), White aluminium (RAL 9006), Jet black (RAL 9005) or “Fashion Collection” colour.

Orga Tower is available in left or right drawer version, equipped with cylinder lock.

Additional castor and counter-weight included as standard for safety reasons.

Fixed height: 950 mm, levelling in range of 10 mm.

Orga Tower – fully assembled as standard.

### 11.3. Product range

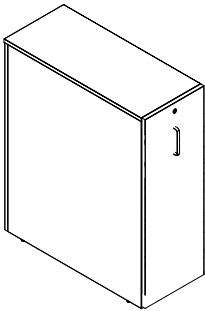

Orga Tower, free-standing with no open part

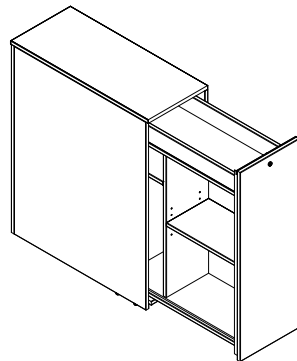

Orga Tower, free standing with pull out drawer

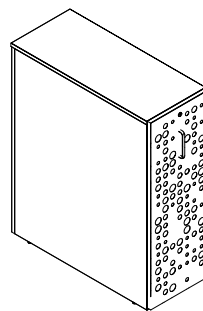

Orga Tower, free-standing with front cover no open part

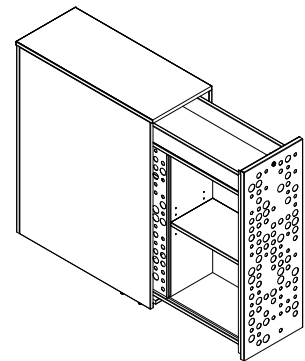

Orga Tower, free standing with front cover and pull out drawer